

# QUICK MOLD CART SYSTEM

快 · 速 · 換 · 模 · 台 · 車 · 系 · 統  
For Injection Molding Machines and Mold Casting Machines



**FORWELL™**

## ▶ 公司簡介 Introduction

富偉公司成立於 1987 年，主要生產自動化、省力化之各式快速換模系統。如沖床快速換模系統、射出機及壓鑄機快速換模系統、印刷電路板沖孔油壓脫料系統及各種自動化夾具快速換模系統。在產品品質及功能方面已深獲使用客戶認同，在穩定成長的同時富偉仍不斷秉持著我們的經營理念「品質榮譽、服務回饋、創新發展」研究開發符合客戶需求的產品，以期能為客戶提供完整的產品。

### **FORWELL PRECISION MACHINERY CO., LTD.**

FORWELL was established in 1987, and is specialized in labor saving press automation equipment such as our Quick Die Change Systems for mechanical presses. The Quick Die Change System works in conjunction with various mold clamping systems for automatic punching presses, injection molding machines, die cast machines, PCB fine piercing and die clamping systems. The quality and functionality of our products are highly regarded by all our customers. We develop new products on a consistent basis, and have a 20 year history of exceeding customer requirements. We offer our machinery to any test.

FORWELL - Quality, Service and Innovation



## ► 換模台車選用指引 Guide to the Quick Mold Cart System

### DCS - 80 - 1

- 1 : 單模具 Single mold
- 2 : 雙模具 Twin mold
- M : 多台共用 Multi-platform use

機台噸數Weight	規格型號Model
1 : ~ 450 t	60
2 : ~ 850 t	80
3 : ~1300 t	100
4 : ~2000 t	120
5 : ~2500 t	160
6 : ~3000 t	180

- D.C.S : 沖床油壓機用  
For hydraulic presses
- M.C.S : 射出機、注塑機用  
For injection molding machines

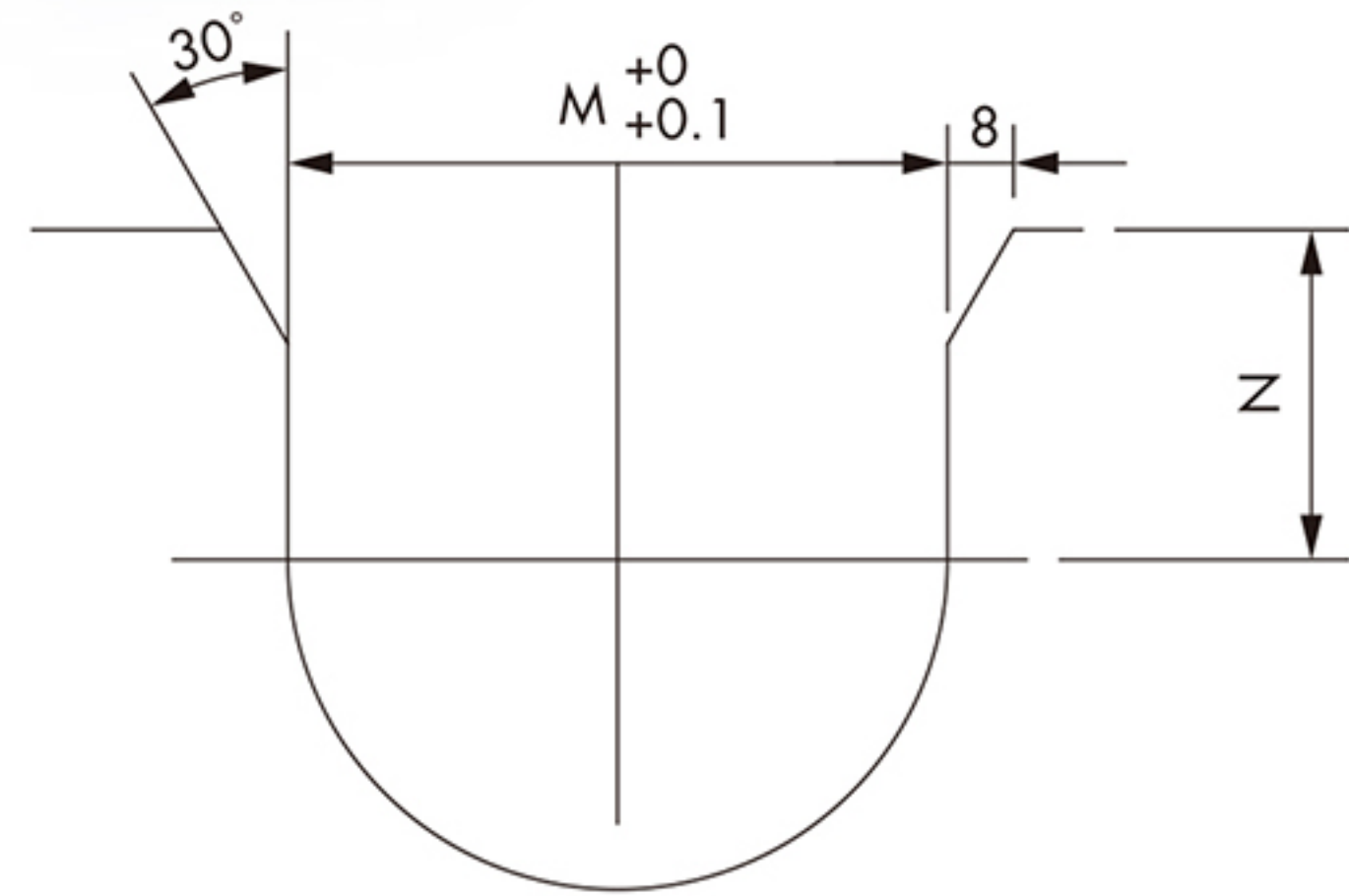

模具定位孔尺寸  
Mold position hole size

註：沖床直接以機台噸數為編碼原則。  
Encode by machine weight.

射出機（注塑機）IMM		夾模器數量 No. of clamping system	盤面滾輪 Rollers	定位孔尺寸 Position hole size	
機台噸數 Weight	夾持力 Clamping force			M (mm)	N (mm)
~450 t	80 t	TFH-10 x 8	60	50	30
~550 t	128 t	TFH-16 x 8	80		
~850 t	128 t	TFH-16 x 8	100	60	38
~1300 t	200 t	TFH-25 x 8	120	80	40
~2000 t	320 t	TFH-40 x 8	160		
~2500 t			180		
~3000 t					

### ■ 客戶須配合事項 Required Items from Customer

1. 機台盤面加工尺寸（裝置物品之固定孔）Work table size (with fixed hold)
2. 機台自動調整模開 Automatic mold opening adjustment  
(輸入模厚參數，機台會自動 +10 ~ 15mm)
3. 機台預留與換模台車的對話功能 Conversational function kept
4. 機台安全門尺寸修改配合 Safety door dimensions
5. 模具定位槽加工 / 模板倒角 Mold locating slot/mold platen chamfer
6. 模具勾拉用固定板加工 Fixed platen for mold pulling

### ▶ 換模台車外觀尺寸圖 Dimensions

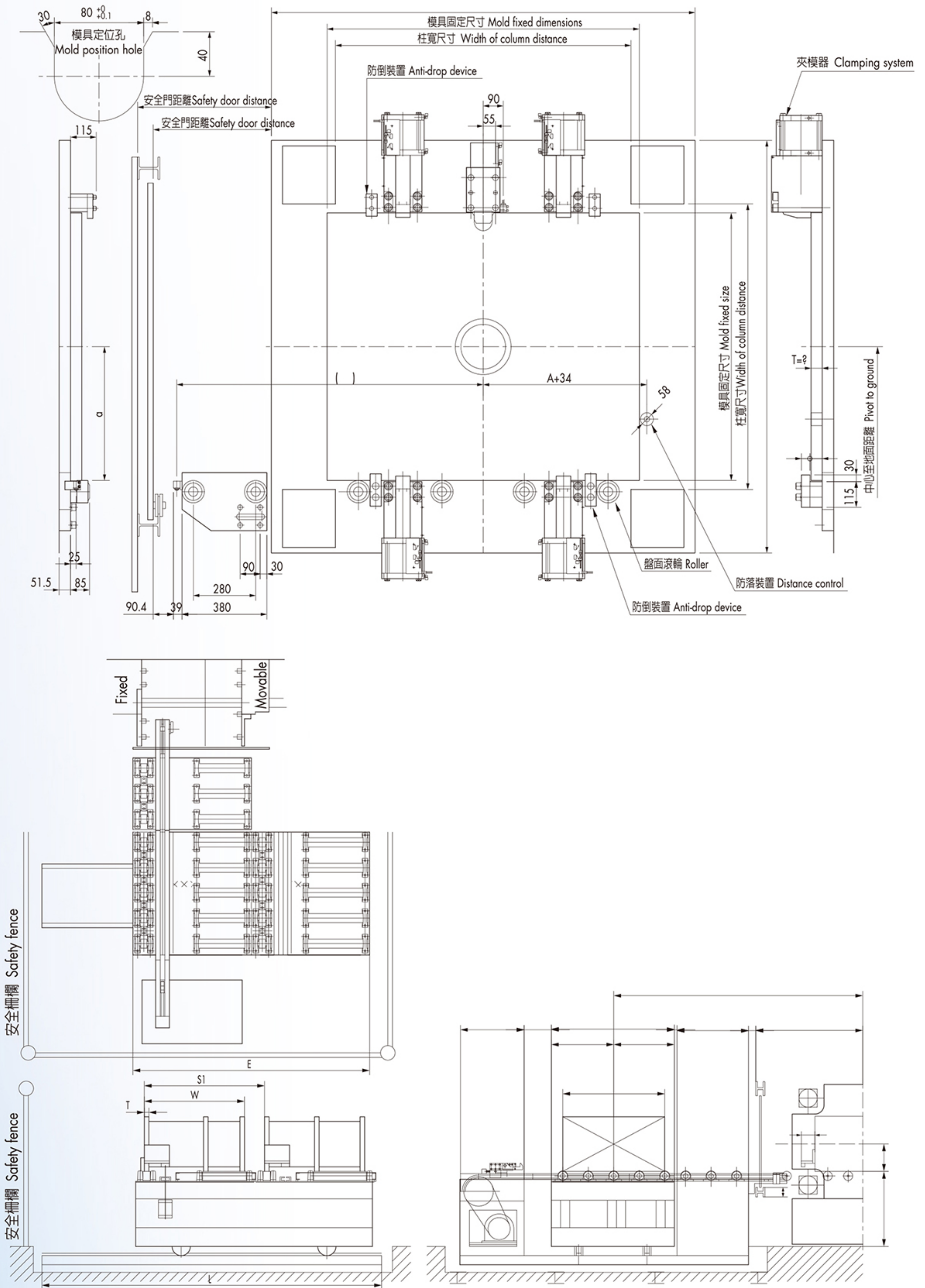

## ▶ 射出機換模台車使用範例 Examples for Injection Molding Machines

- 單機單模固定式  
Fixed type for single mold machine

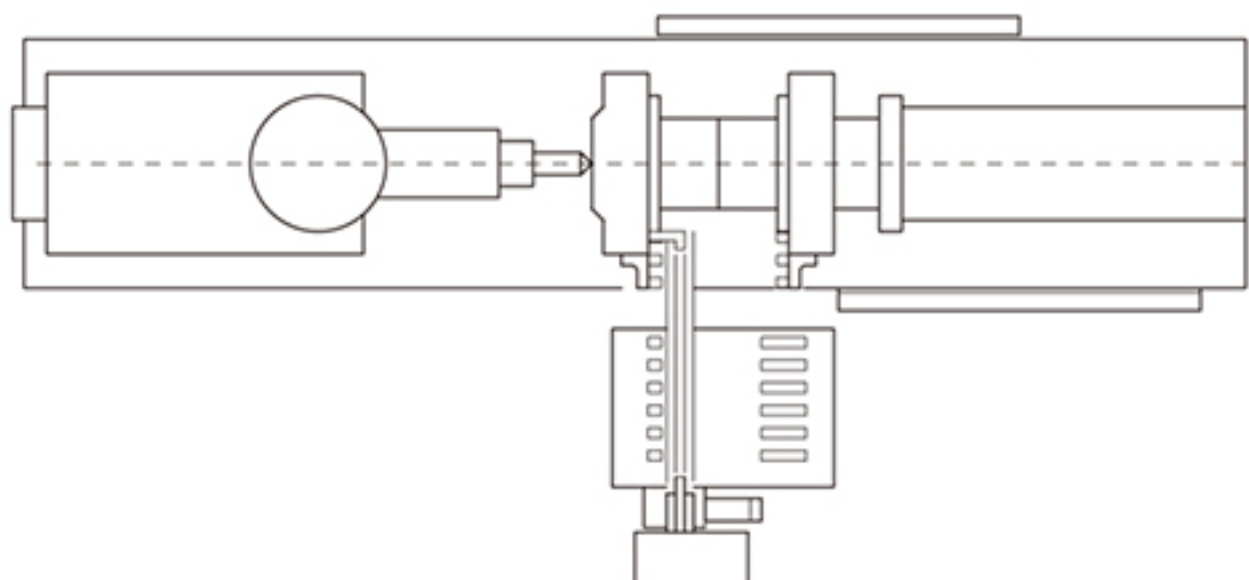

- 單機雙模移動式  
Moving type for twin mold machine

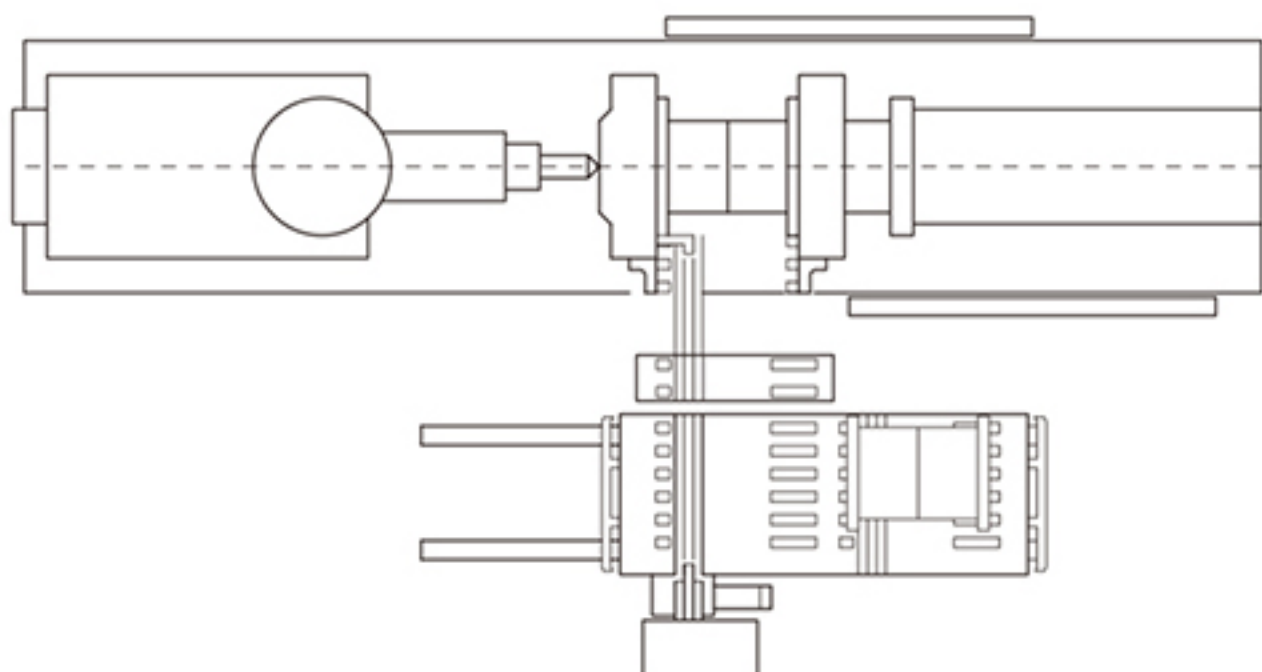

- 多機雙模移動式（推拉裝置固定式）  
Twin mold moving type for multiple machines

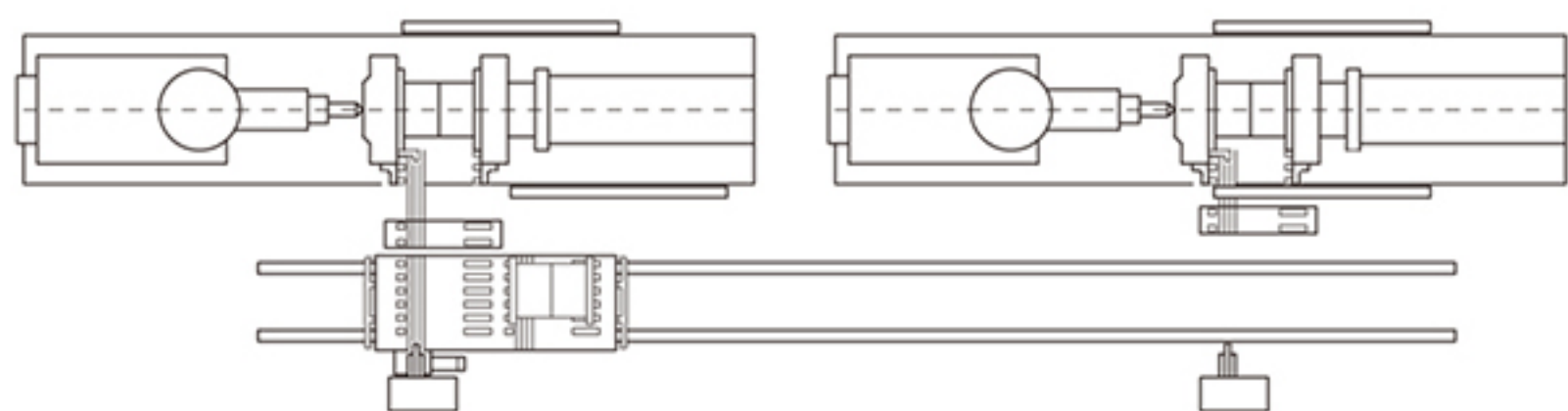

- 直列式共同移動台車  
In-line moving type

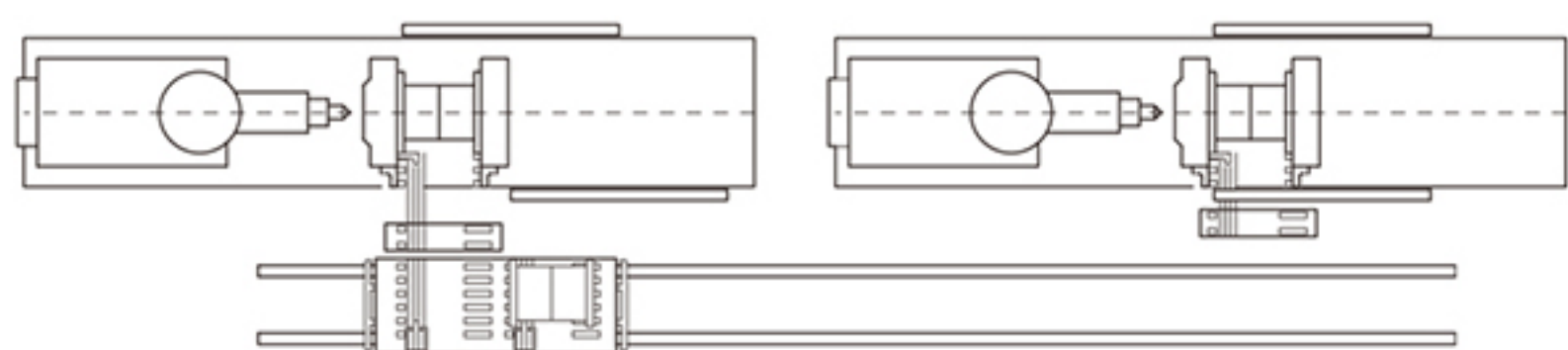

- 雙向移動式（設備方向相反）  
Bidirectional moving type  
(Machines are opposite directions)

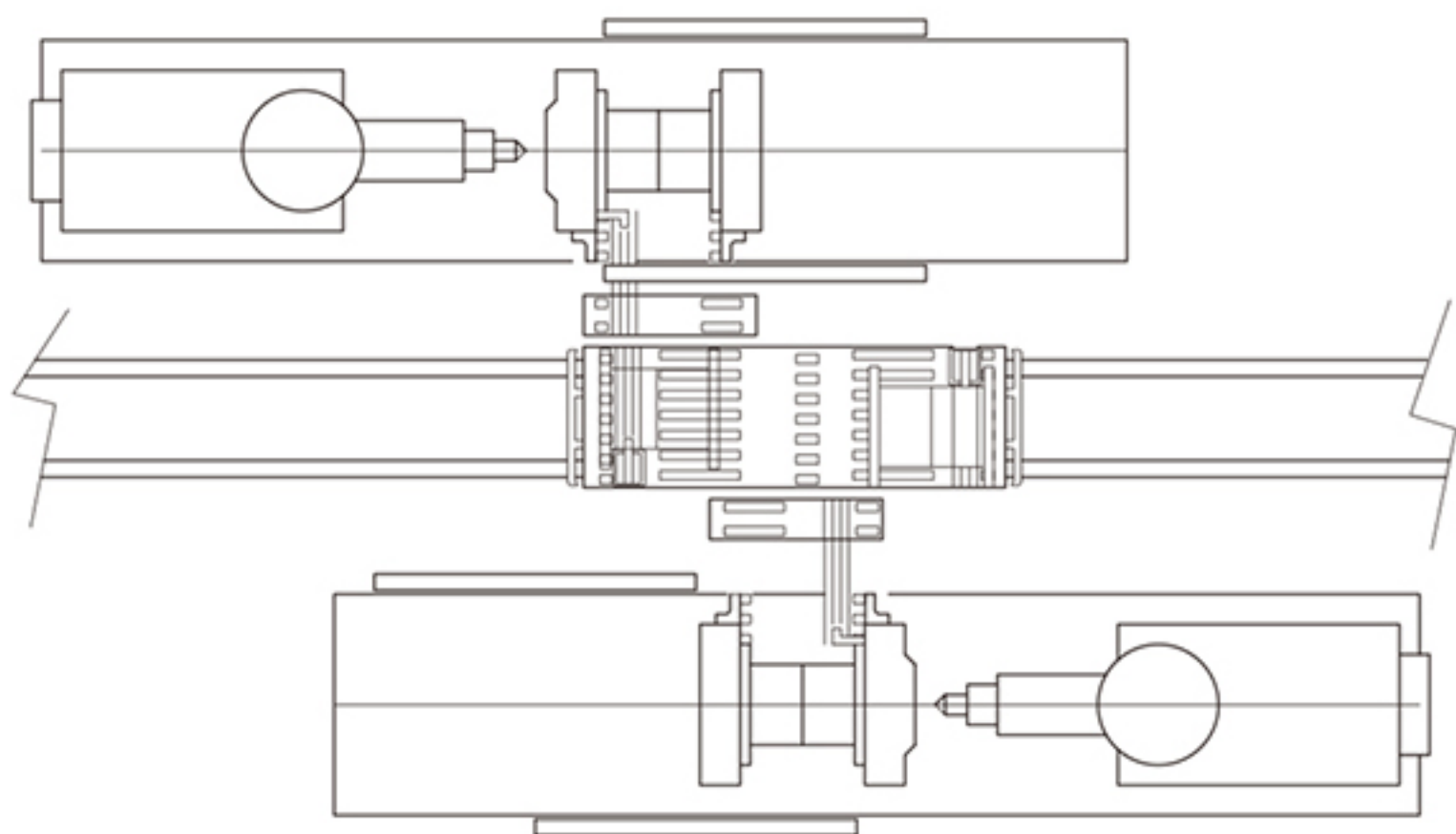

## ▶ 沖床換模台車使用範例 Examples for Presses

- 單機雙模移動式  
Moving type for twin mold machine

側向入模，避免機械手阻礙。  
Horizontal mold loading for avoiding robot.

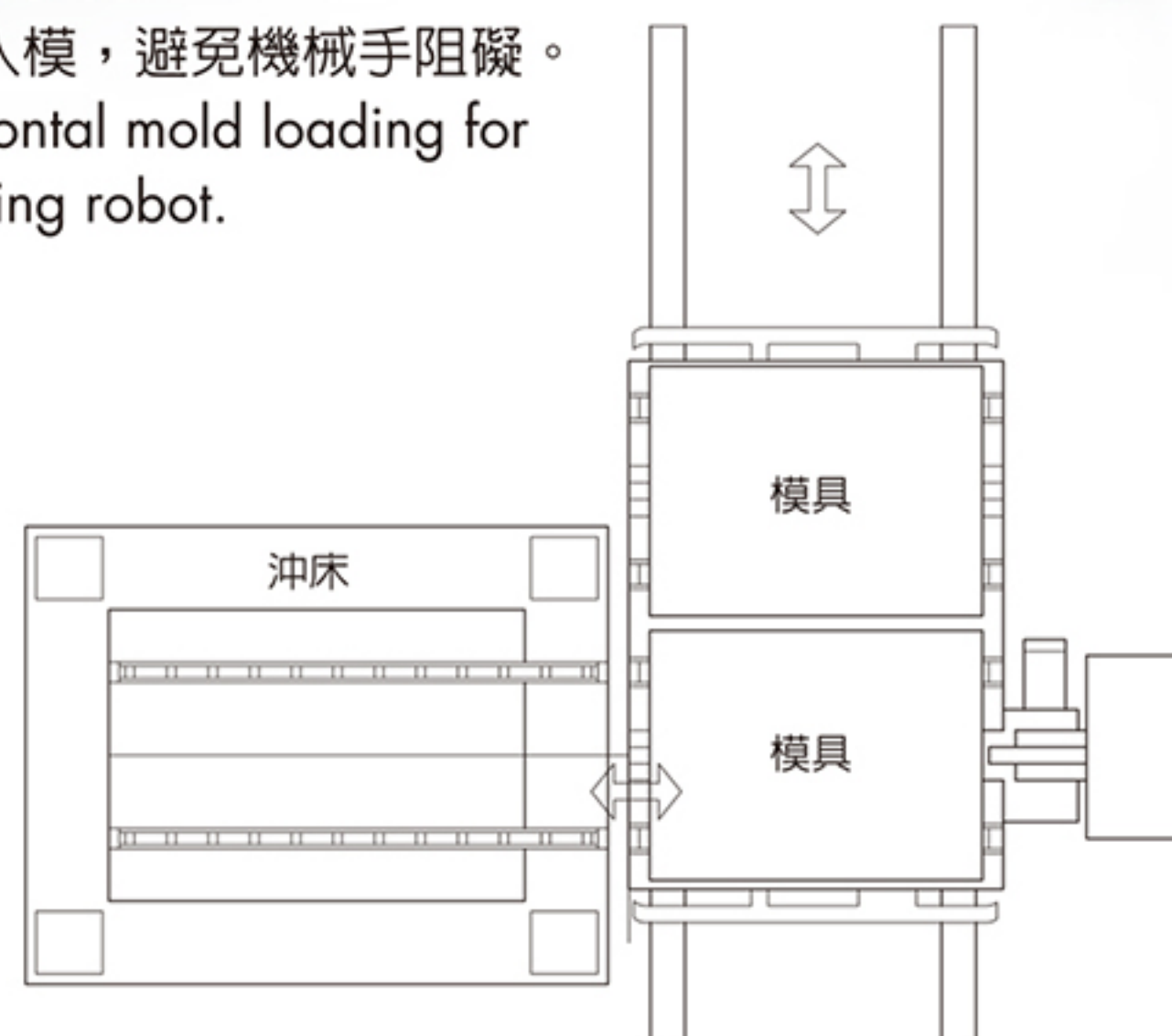

- 直列式共同移動台車 In-line moving type

使用移動軌道和移動台車進行換模，可多台共用，適用範圍較廣。

Die change operation using a powered 2-die cart. The widest application is possible.

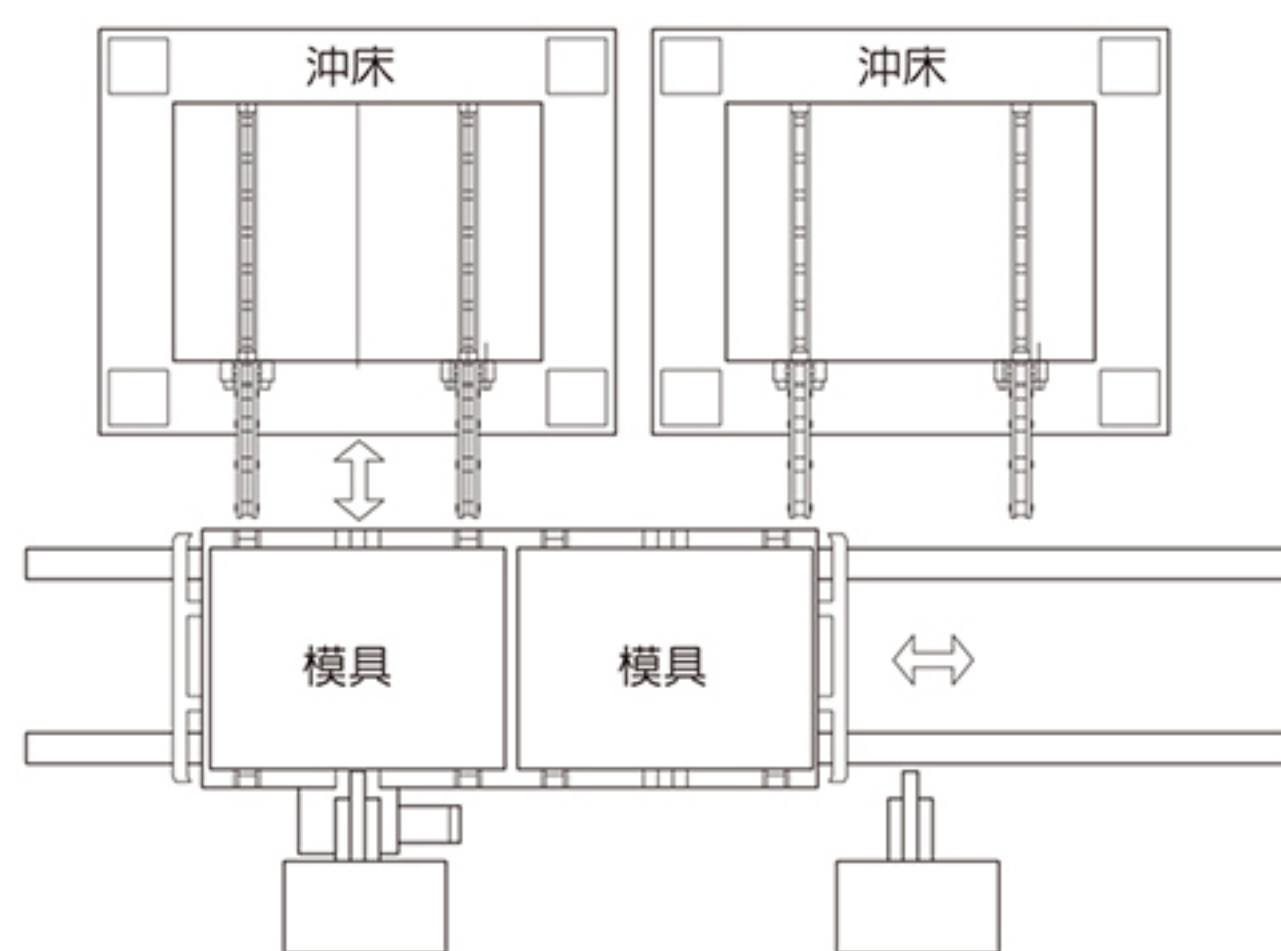

- 雙向移動式 Bidirectional moving type

雙模雙台車同步進行，在最短時間內更換模具，節省換模時間。

Simultaneous 2-die change operation using two carts. The shortest die change time is achieved.

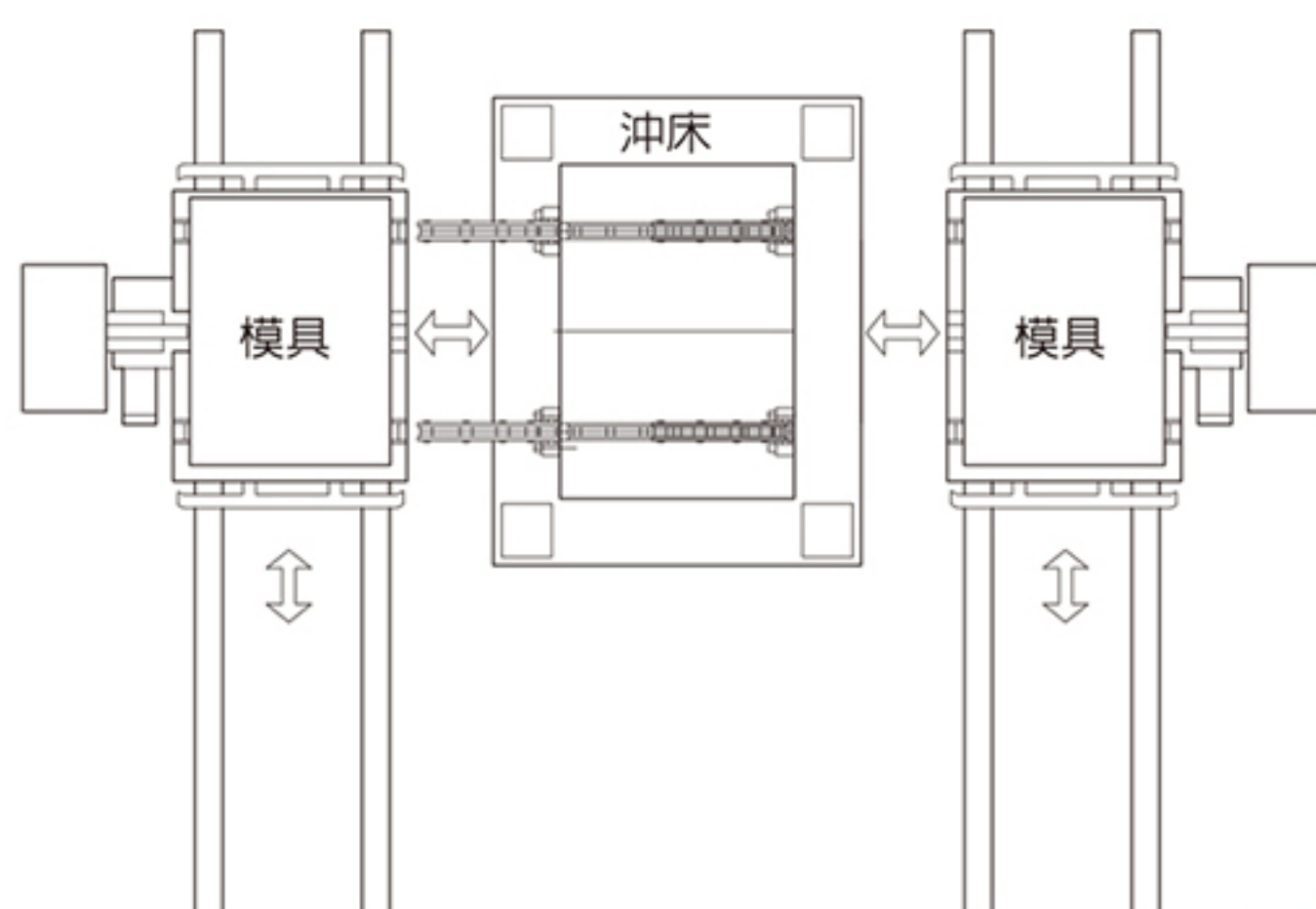

### ► 氣壓固定式夾模器 Pressure Clamps

此型夾模器利用氣壓以彈簧及偏心凸輪原理作動，夾持模沿。  
Uses air driven with spring and accentric cam to clamp the mold.

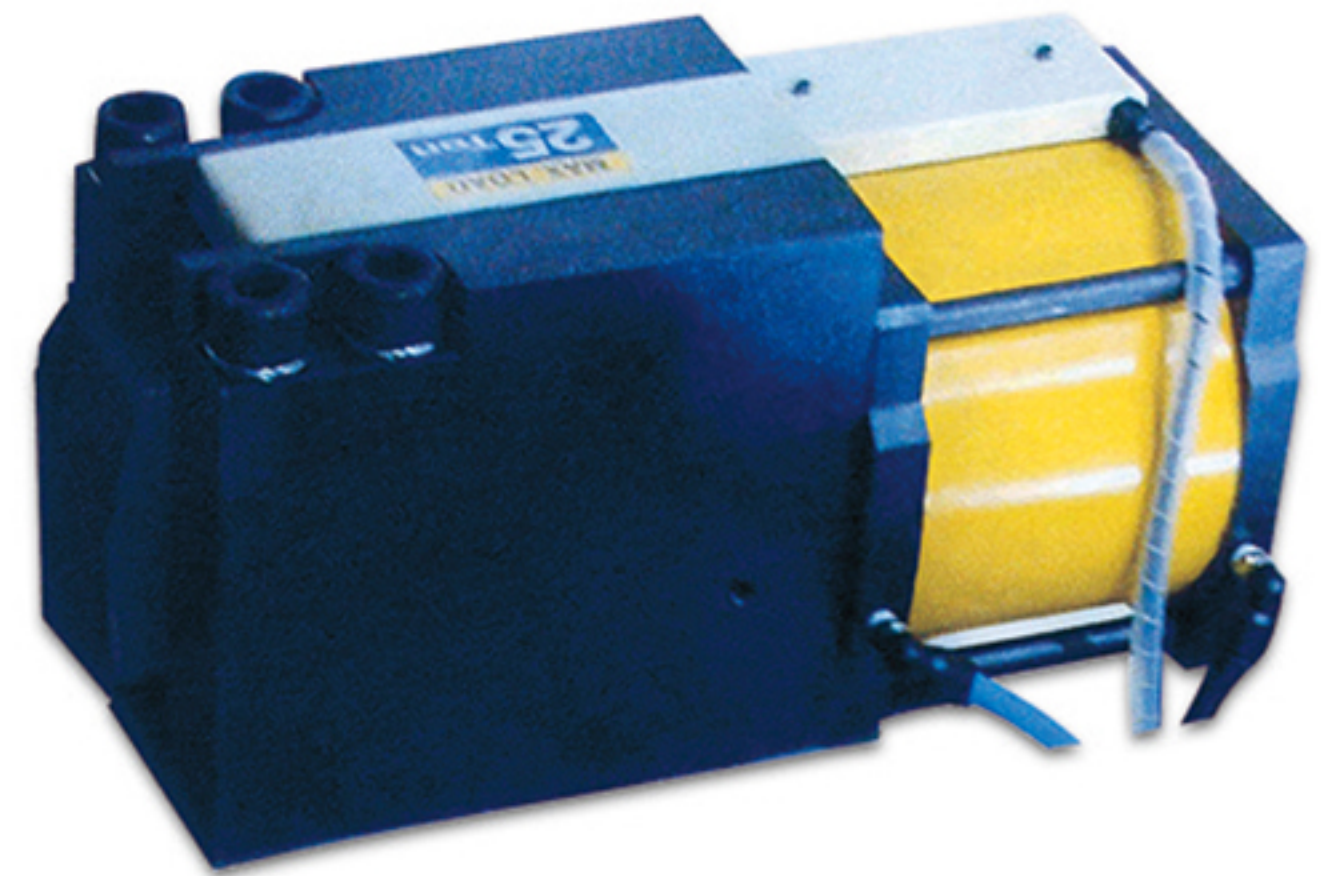

### ► 外型尺寸 Dimensions

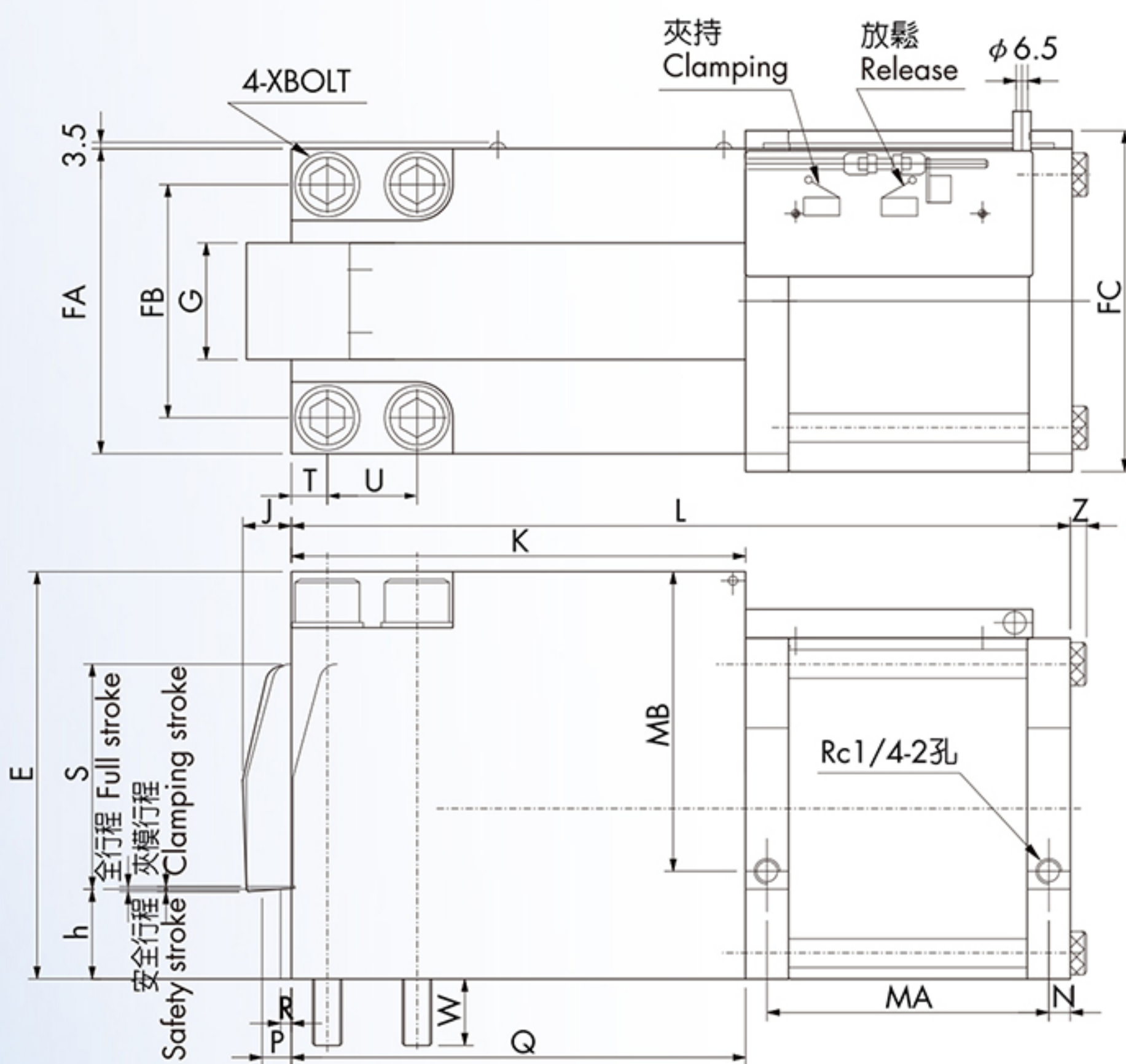

### 特性規格 Specifications

Model	TFH-10	TFH-16	TFH-25	TFH-40
夾持力 (kN) Clamping Force	98	157	245	310
固定壓力 Fixed pressure (kN)	空氣壓力 0.39MPa Air pressure	98	157	245
	空氣壓力 0MPa Air pressure	26.5	40.9	65
夾模力 Clamping force (kN)	空氣壓力 0.49MPa Air pressure	75.5	124	190
	空氣壓力 0.39MPa Air pressure	63.7	104	160
	空氣壓力 0MPa Air pressure	14.7	23.5	35
全行程 Full stroke (mm)	2.8	3	3.3	4
夾模行程 Clamping stroke (mm)	1.2	1.2	1.3	1.5
安全行程 Safety stroke (mm)	1.6	1.8	2	2.5
汽缸容量 Cylinder capacity (cm) <sup>3</sup>	夾模時 Clamping	773	1334	2468
	放鬆時 Release	729	1262	2346
使用壓力 Pressure (MPa)	空氣壓力 (MPa)標準 Air pressure	0.49		
	空氣壓力 (MPa)最小 Air pressure	0.39		
工作溫度 Work temperature	70°C			
使用頻率 Using frequency	20/日			

Model	E	FA	FB	FC	G	J	K	L	MA	MB	N	P	MIN.Q	R	S	T	U	W	X	Z	標準H
TFH-10	156	135	95	130	48	19	164.5	299.5	119	115.5	8.5	11	163.5	3	98.5	13	32.5	36	M12	6	40±0.3
TFH-16	182	142	104	160	55	23	203	360	128	132	12	13	203	5	100.5	17	40	30	M20	6	40±0.3
TFH-25	227	170	130	190	65	25	253	434	158	167	12	17	245	5	125.5	20	50	37	M24	10	50±0.3
TFH-40	247	200	146	210	80	25	253	454	170	178	15	17	255	5	145.5	27	60	37	M30	20	50±0.3

## ▶ 訂購資料表 Quotation Information Form

射出機型式 IMM type  新設 New \_\_\_\_\_ ton  舊有 Existing \_\_\_\_\_ ton

台數 No. of machines \_\_\_\_\_

射出能力 Injection capacity \_\_\_\_\_

### 模具尺寸 Mold Size

寸法 Dimensions	E	Max.	Min.
	F	Max.	Min.
	G	尺寸固定 Fixed size	
	H	尺寸固定 Fixed size	
	J	Max.	Min.
重量 Weight	Max.		
定位位置 Position	<input type="checkbox"/> 標準 Standard		<input type="checkbox"/> 特殊 Special

### 模具外型尺寸圖 Die Dimensions

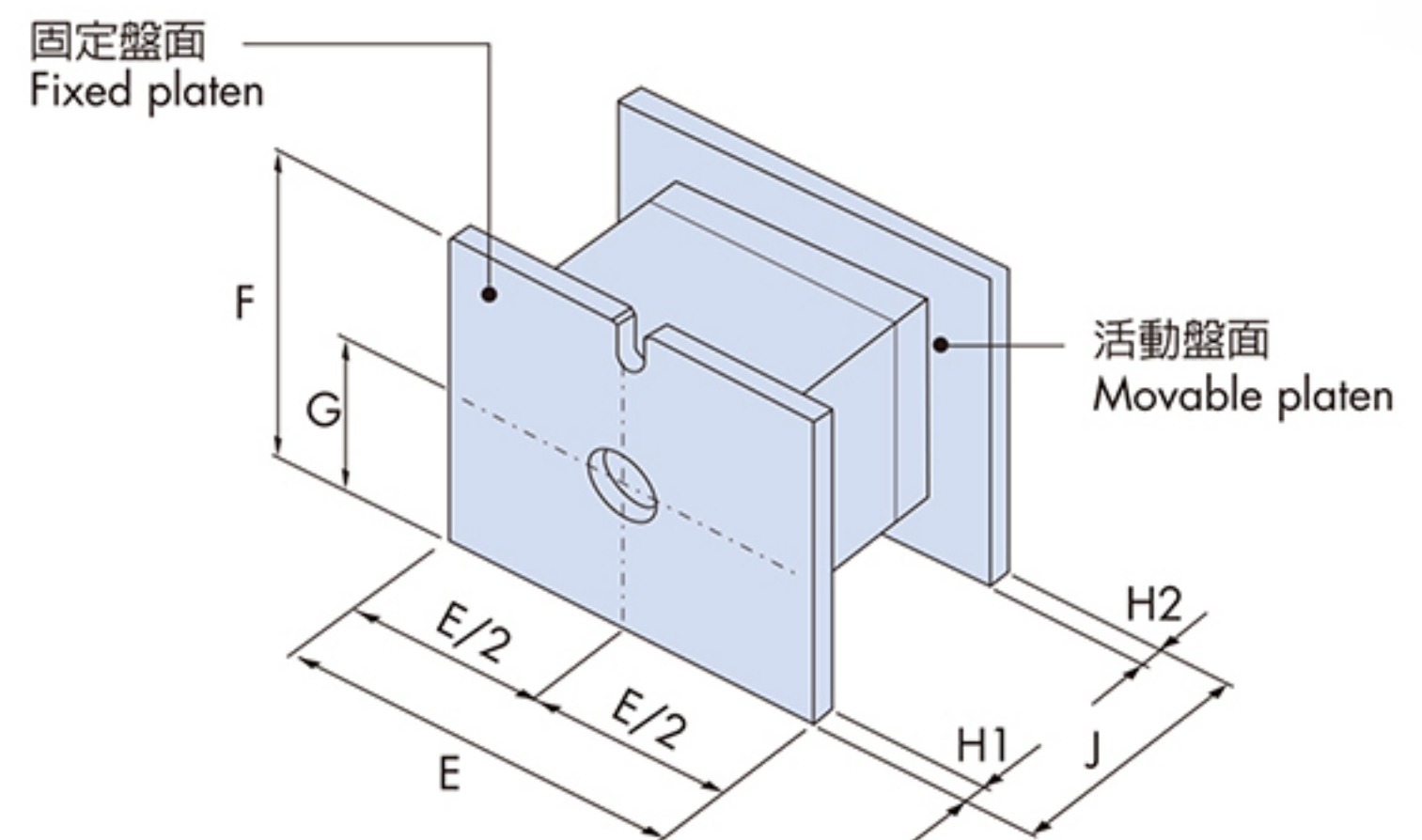

● 定位孔加工尺寸，請參考前第 2 頁  
Please refer to Page 2 for position hole size.

### 配合尺寸 Fitting Size

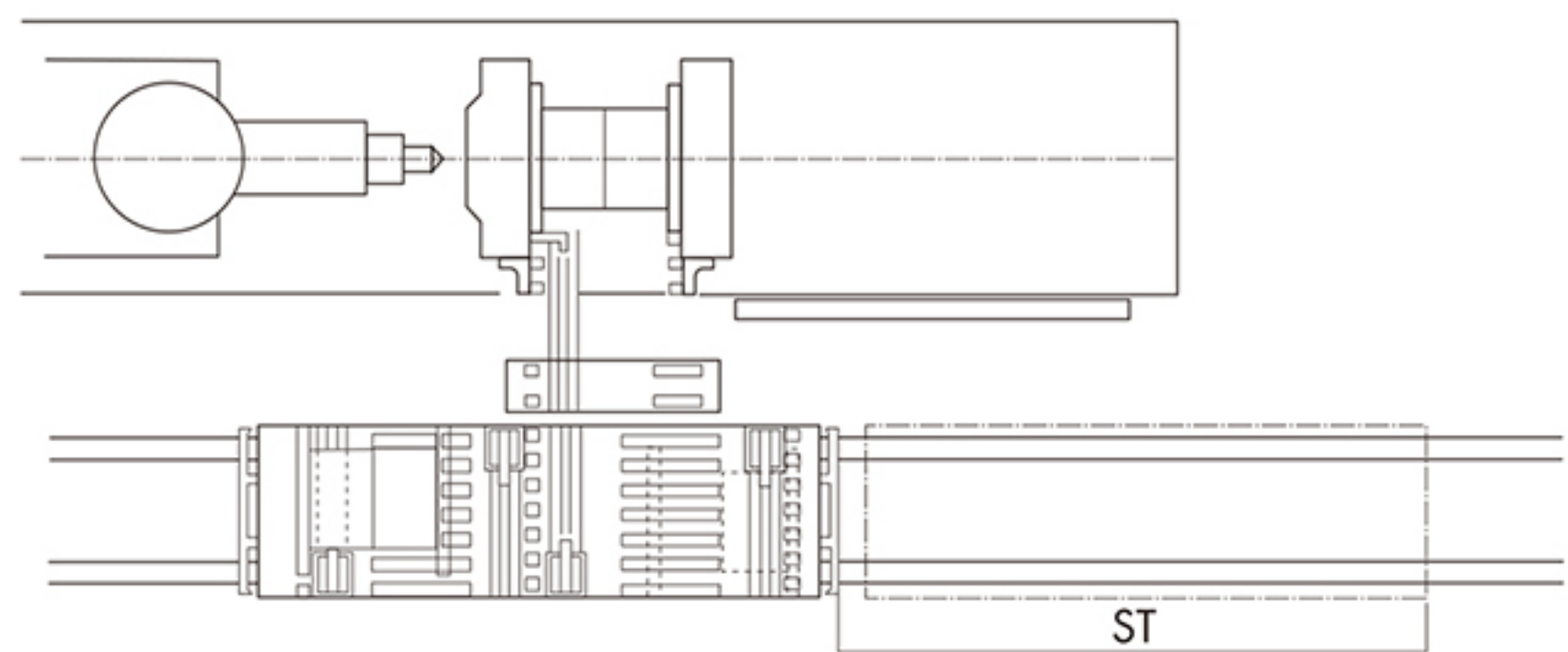
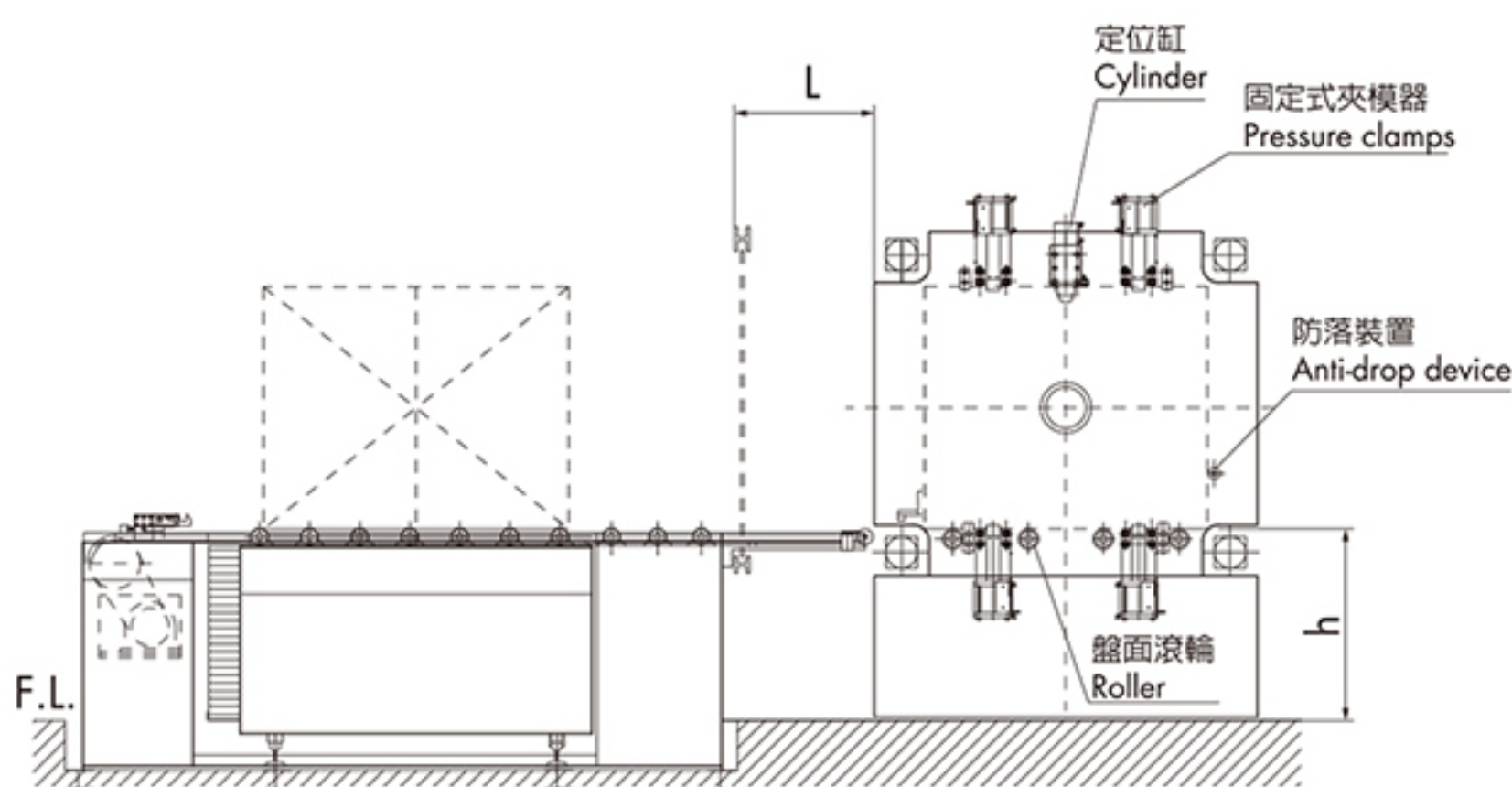

a. 滾輪頂點高 Roller height	h
b. 安全門距離 Safety moving door distance	L
c. 台車行走距離 Cart moving distance	ST
d. 操作方式 Operations	<input type="checkbox"/> 機台連線 Linkage <input type="checkbox"/> 個別操作 Individual
e. 電源、電壓 Voltage	
f. 地面施工 Ground construction	<input type="checkbox"/> 有軌道 Railway <input type="checkbox"/> 無軌道 Without railway

特殊事項 (使用溫度) Temperature :  常溫 Normal \_\_\_\_\_ °C  高溫 High \_\_\_\_\_ °C

### 基本資料 Form

公司名稱 Company / \_\_\_\_\_

連絡人 Attn. / \_\_\_\_\_

地址 Add. / \_\_\_\_\_

電話 Tel. / \_\_\_\_\_

傳真 Fax. / \_\_\_\_\_



## FORWELL PRECISION MACHINERY CO., LTD.

No. 399, Sec. 2, Mingsheng Rd., Pusin Township,  
Changhua County 51346, Taiwan  
TEL: +886-4-834-5196 FAX: +886-4-834-5197  
<http://www.forwell.com>  
E-mail: [forwell@forwell.com](mailto:forwell@forwell.com)

The way of viewing COMPANY PROFILE of FORWELL:  
Please visit the website [view.forwell.com](http://view.forwell.com) and key in the  
video serial number  **EA19601** to watch the  
product running in actual production environment.

## 富偉精機股份有限公司

公司地址：51346 台灣彰化縣埔心鄉經口村明聖路二段 399 號  
TWGPS: N23° 56'51.00" E120° 33'26.26"

富偉公司簡介之影片瀏覽方式：

請輸入網址 [view.forwell.com](http://view.forwell.com) 再輸入影片編號

 **CA19601** 即可線上瀏覽動態影片



富偉科技集團 台灣



富偉科技集團 寧波

**NINGBO BRANCH**      Headline: +86-133-8574-9196  
No. 8, Jin-cheng Rd., Zhenhai Economic Development Zone,  
Ninbo, Zhejiang, China 315200  
TEL: +86-574-8659-9196 FAX: +86-574-8659-9197

Shenzhen office:  
C3, 3F, Building 4, Shangxiawei Creative Industrial Park,  
Shasan Village, Shajing Town, Baoan District, Shenzhen,  
China 518104  
TEL: +86-755-2751-3796 FAX: +86-755-2751-3797

## 富偉精密機械(寧波)有限公司

中國寧波廠：                      企業總機：+86-133-8574-9196  
中國浙江省寧波市鎮海經濟開發區金誠路 8 號  
郵編：315200  
NBGPS: N29° 56'29.50" E121° 40'49.00"

深圳辦事處：  
深圳市寶安區沙井街道沙三上下圍第三工業區創業工業區  
4 棟 3 樓 C3                      郵編：518104

